

tyco

Waterworks Polska

Tyco Waterworks Polska Sp. z o.o.
PL 41-600 Świętochłowice, ul. Plebiscytowa 3

QUART 2000 WEDGE GATE VALVE

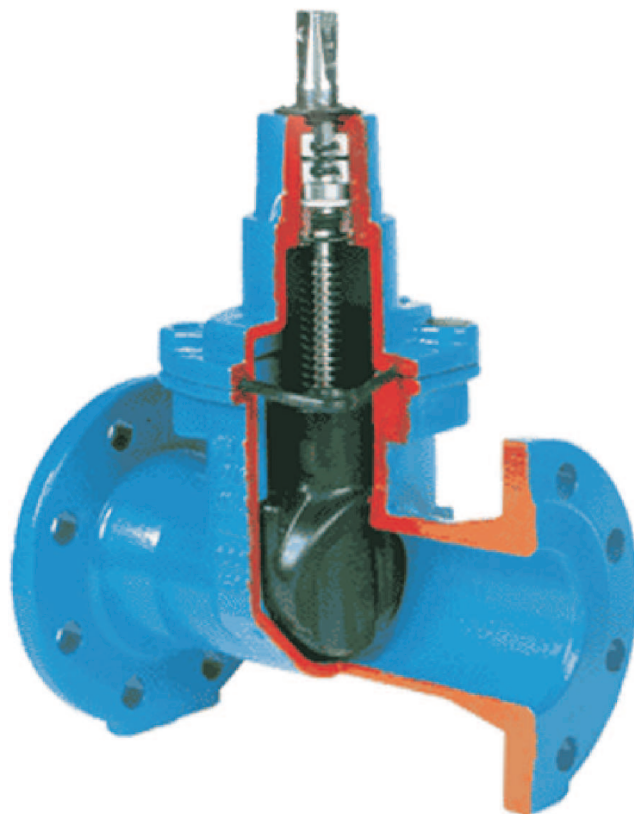

**МЕТАЛЛИЧЕСКИЕ
МАТЕРИАЛЫ**

ЗАО «Мет Мат»
www.metmat.ru info@metmat.ru
тел.: (495) 545-93-66 факс: (495) 545-93-66
Россия, 107113, г. Москва, Сокольническая пл., д. 4А

QUART 2000 WEDGE GATE VALVE

Made from ductile cast iron or ductile cast steel.
 For water and gas.

Made according to the standards: DIN 3352 - PN 16 - 4 B
 For water DIN 3230 part 4, for gas: DIN 3230 part 5

Pressure tests made according to DIN-DVGW for water and gas: DIN 3547 part 1

TECHNICAL DATA

QUART 2000 wedge gate valve type A

QUART 2000 wedge gate valve type B

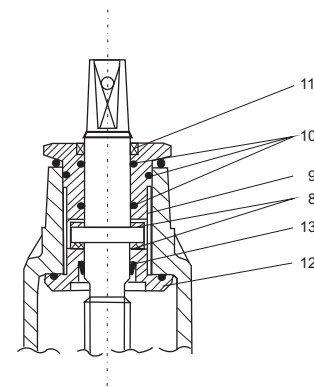
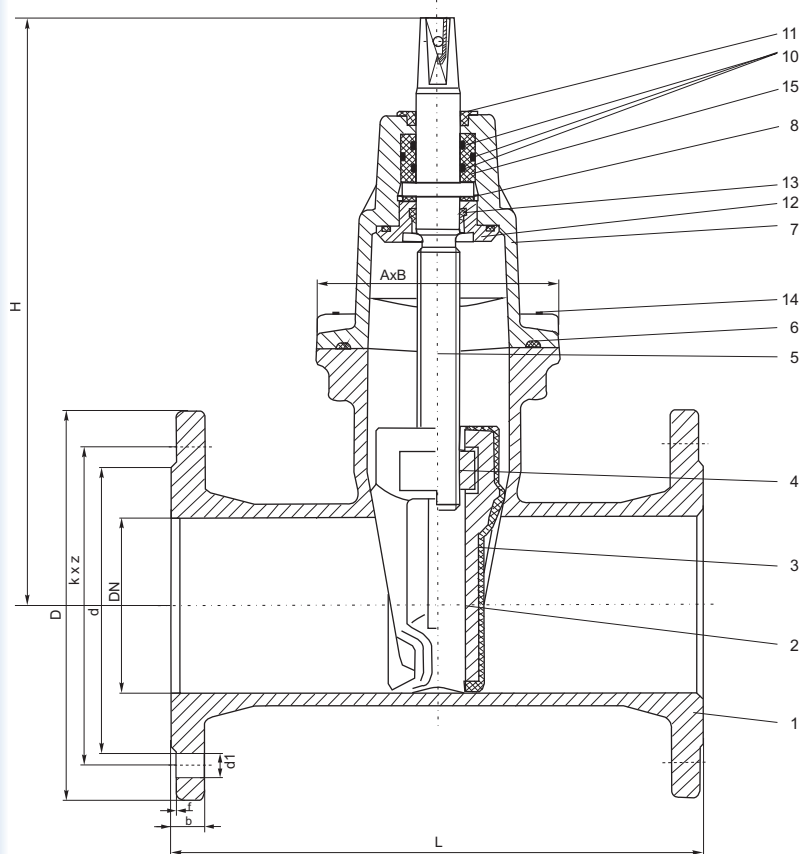

Item	Part	Material
1	body	Ductile cast iron GGG or cast steel GS-C 25 N
2	wedge	Ductile cast iron GGG-50
3	wedge rubber sealing	NBR or EPDM
4	stem nut	brass
5	stem	1.4571 or 1.4021
6	cover seal	NBR
7	cover	Ductile cast iron GGG or cast steel GS-C 25 N
8	sliding disk	polyamide
9	o-ring bushing	G-CuAl 10 Ni
10	o-ring	NBR
11	scraping gasket	NBR
12	locking screw	CuZn 40 Pb 2
13	o-ring - scraper	NBR
14	screws	A 2
15	o-ring bushing	polyamide

DN	L [mm]		H [mm]	A [mm]	B [mm]	D [mm]	d [mm]	f [mm]	k		z		type of screw flange connection		d1		b [mm]	Weight [kg]	
	F4	F5							PN 10	PN 16	PN 10	PN 16	PN 10	PN 16	PN 10	PN 16		F4	F5
40	140	240	230	75,2	120,5	150	84	3	110	110	4		M16		19	19	8,0	9,0	
50	150	250	245	83,5	123,0	165	99	3	125	125	4		M16		19	19	10,0	11,0	
65	170	270	275	101,5	133,5	185	118	3	145	145	4		M16		19	19	12,5	13,5	
80	180	280	305	129,5	151,5	200	132	3	160	160	8		M16		19	19	17,0	18,5	
100	190	300	330	138,0	176,0	220	158	3	190	180	8		M16		19	19	21,0	22,5	
125	200	325	375	144,0	201,0	250	184	3	220	210	8		M16		19	19	29,5	32,0	
150	210	350	415	163,0	232,0	285	211	3	250	240	8		M20		23	19	38,0	41,0	
200	230	400	510	173,0	303,0	340	266	3	294	295	8	12	M20		23	20	58,0	66,0	
250	250	450	620	182,0	336,0	400	319	3	350	355	12		M20	M24	23	28	22	85,5	100,5
300	270	500	700	194,0	397,0	455	376	4	400	410	12		M20	M24	23	28	24,5	121,0	141,0
350	290	550	700	194,0	397,0	520	432	4	460	470	16		M20	M24	23	28	24,5	136,0	150,0
400	310	600	880	255,0	575,0	580	485	4	515	525	16		M24	M27	28	31	31	285,0	
500	350	700	1070	300,0	710,0	715	700	4	620	650	20		M24	M30	28	34	34	525,0	

* - body DN 300

QUART 2000 WEDGE GATE VALVE

THE WEDGE GATE VALVE STRUCTURE

- Full **non-socket** flow.
- **Stem** made from stainless steel, with straight thread, with hole for connection with the casing.
- The sealing **bushing** with o-rings, totally separated from the utility /water or gas/.
- **The scraping gasket and o-ring scraper**
 - prevent the contaminants getting into the sealing bushing, both from the utility flowing through and from the soil.
- **The wedge** entirely rubberized, including the inside surfaces, long guiding the wedge with little clearance in the guide, **double sealing lip applied**.
- **Screws** made from A2 material, entirely sunk in the body, additionally protected with silicone layer.
- The structure of **type A** wedge gate valve
 - standard make, with possibility of entire dismantling the gate valve without damaging the particular elements (upon cutting off the utility).
- In **type B** wedge gate valve, the stem sealing is replaced under pressure without damaging the particular elements.
- Thanks to the flexible coupling between the stem and the wedge the total loads are transmitted from the wedge onto the body and not on the stem and o-rings.
- The wedge gate valve **build-in length**: short acc. DIN 3202 F4, long acc. DIN 3202 F5.

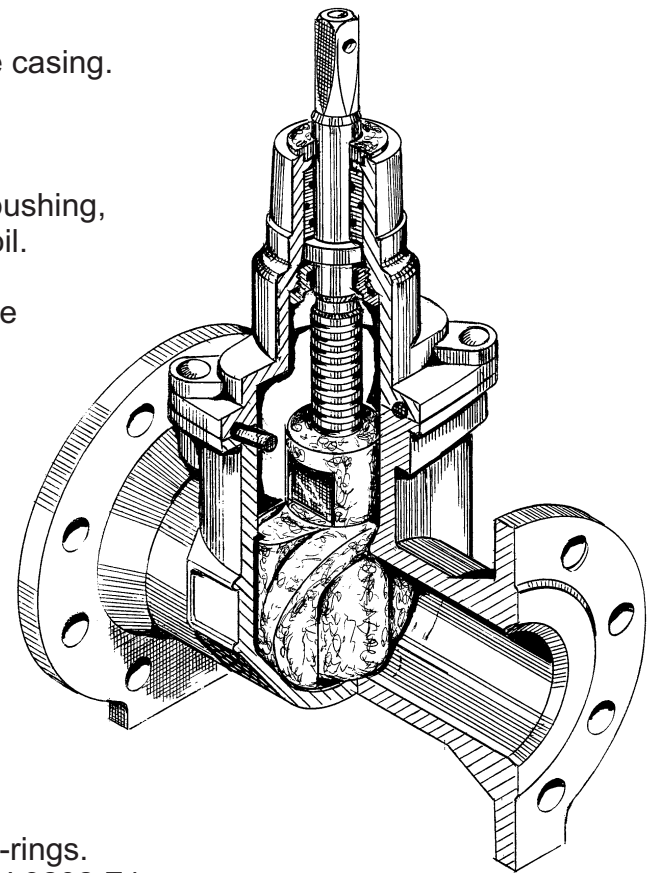

Cast steel wedge gate valves - long build-in only acc. DIN 2501 PN 10 and PN 16.

- Additional accessories:

- drive: hand - wheel or electric;
- stem extension rods: of constant or telescopically regulated length;
- wedge gate valve case from cast iron.

All QUART 2000 wedge gate valves from ductile cast iron are covered with epoxy resin with the fluidization method, as recommended by Stowarzyszenie Ochrony Antykorozyjnej [Anti-corrosion Protection Association] (GSK) and are marked with RAL quality certification logo.

At request, the wedge gate valves may be enamel-coated and the wedge rubberizing and seals may be made from EPDM.

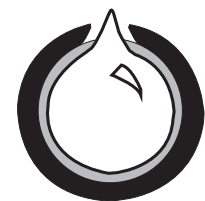

RAL ZNAK JAKOŚCI
 OCHRONY ANTYKOROZYJNEJ
 ARMATURY I KSZTAŁTEK

LEAK PROOF TESTS

Each manufactured wedge gate valve is subjected to leak proof tests:

DN	PN (bar)	Water wedge gate valve		Gas wedge gate valve		
		casing	lock	test	casing	lock
40 - 350	up to 16	1,5 x PN	PN	PG 1	0,5	0,5
				PG 2	0,5 i 1.1 x PN	0,5 i 1.1 x PN

QUART 2000 WEDGE GATE VALVE

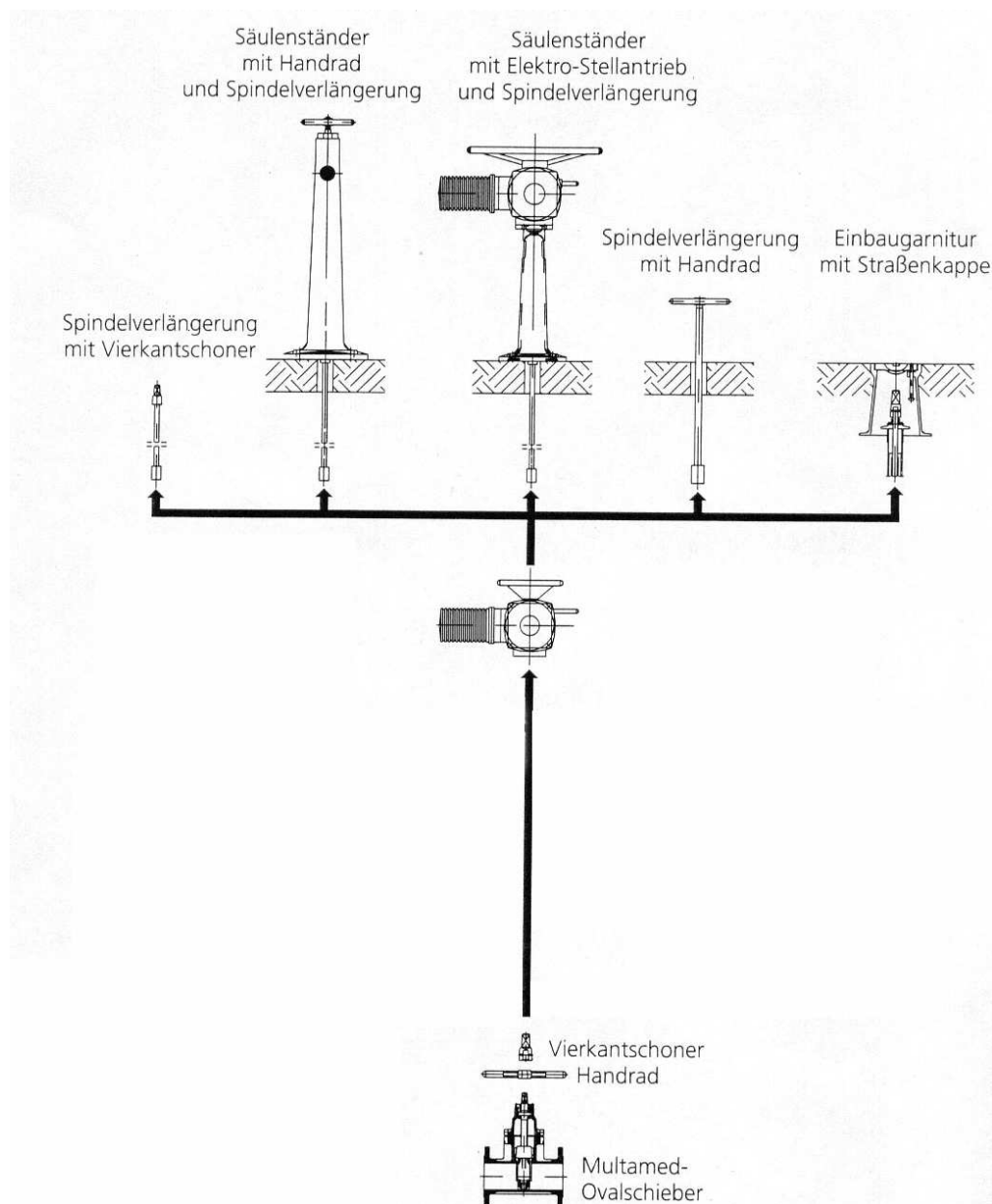

Additional accessories:

- drive: hand-wheel or electric;
- stem extensions: with constant or telescopically regulated length;
- ductile cast iron gate valve box.

QUART 2000 WEDGE GATE VALVE

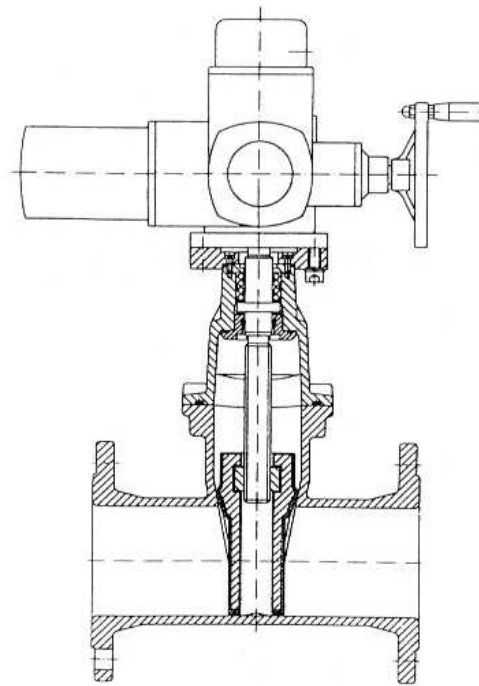
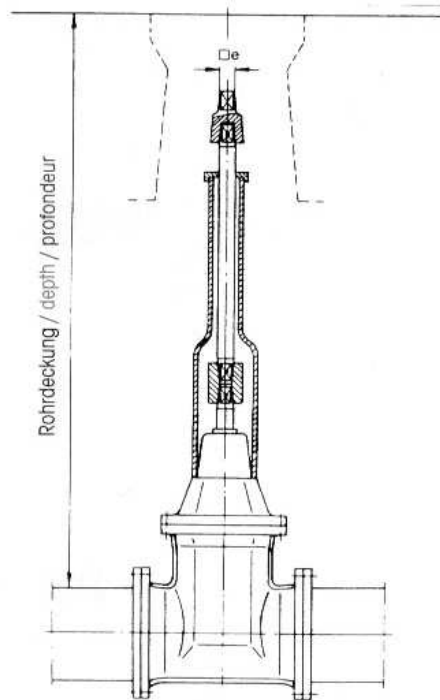

Typ / type / figure C

Wedge gate valve with mandrel extension
- for the box

Wedge gate valve with electric drive

LEAK PROOF TESTS

Each manufactured gate valve is subjected to leak proof tests

QUART 2000 WEDGE GATE VALVE

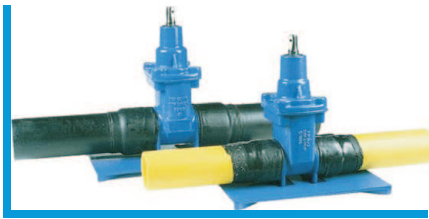

QUART 2000 WEDGE GATE VALVE

With PE outlet terminals
For water PN 10 and PN 16
Gas PN 4
DN 25 - DN 200



QUART 2000 WEDGE GATE VALVE PN 10 and PN 16

With TYTON-TKF-Z connection
With soft sealing DN 80 - DN 300
For cast iron pipes
Two make variants
Faucet - faucet
Faucet - bare terminal



QUART 2000 WEDGE GATE VALVE PN 10 and PN 16

With bare terminals
For water and sewage
With soft sealing
DN 80 - DN 300

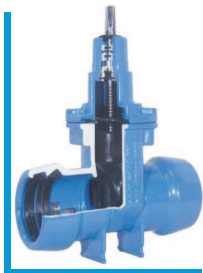

QUART 2000 WEDGE GATE VALVE PN 10 and PN 16

With PEZ connection for PE pipes
For water and sewage
With soft sealing
DN 80 - DN 200

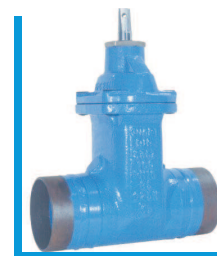

QUART 2000 WEDGE GATE VALVE PN 10 and PN 25

Cast steel flange or with terminals for welding
For water and gas
With soft sealing
DN 40 - DN 300



QUART 2000 WEDGE GATE VALVE PN 10 and PN 16

With connection for PVC pipes
For water and sewage
with soft sealing
DN 50 - DN 200



QUART 2000 WEDGE GATE VALVE, flange F4, F5

For water, gas and sewage
PN 10 and PN 16,
With soft sealing,
DN 40 - DN 500

In process of start-up:

- QUART 2000 wedge gate valves with faucet and bare terminal
- QUART 2000 wedge gate valves with flange and bare terminal